



Can CCPM create \$1b value?

A case study

Johan Steyn





Johan Steyn

Specialisation:

- Project/Programme/Portfolio management
- Strategic governance of organisational performance
- Operations optimisation and operational turnaround
- Organisational competitiveness

Industry experience:

Infrastructure, capital projects, water and electricity utilities, manufacturing, financial services, public sector, mining, ICT, engineering, aviation, agriculture, strategic change programmes and public sector services.



Johan.Steyn@za.pwc.com

083 702 2354





Problem statement

- A power utility has limited capacity
- If demand exceeds capacity, can CCPM
 - Reduce capital requirement?
 - Delay capital investment
 - Provide capacity sooner than a capital investment programme?



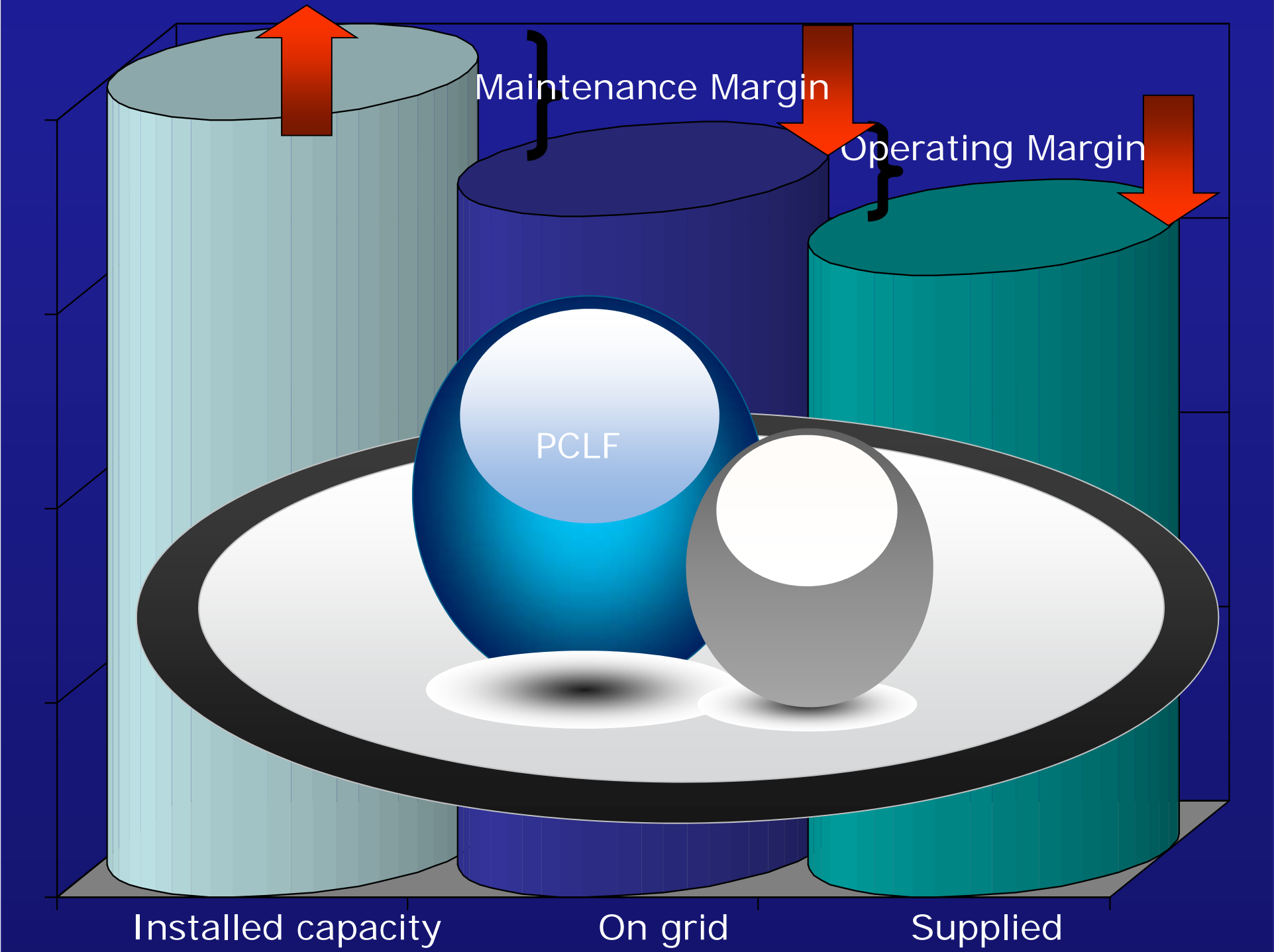



Outage Schedule

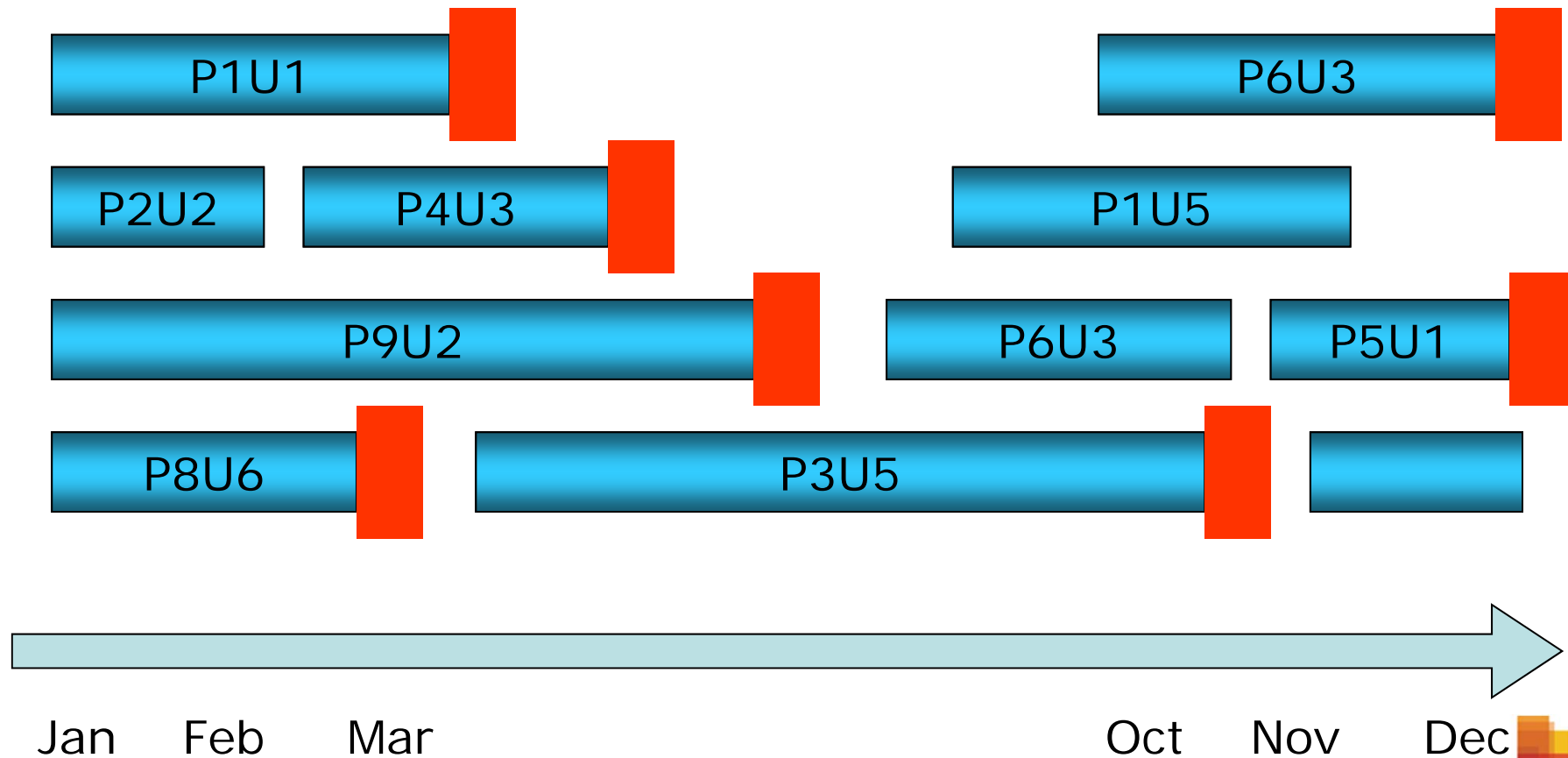

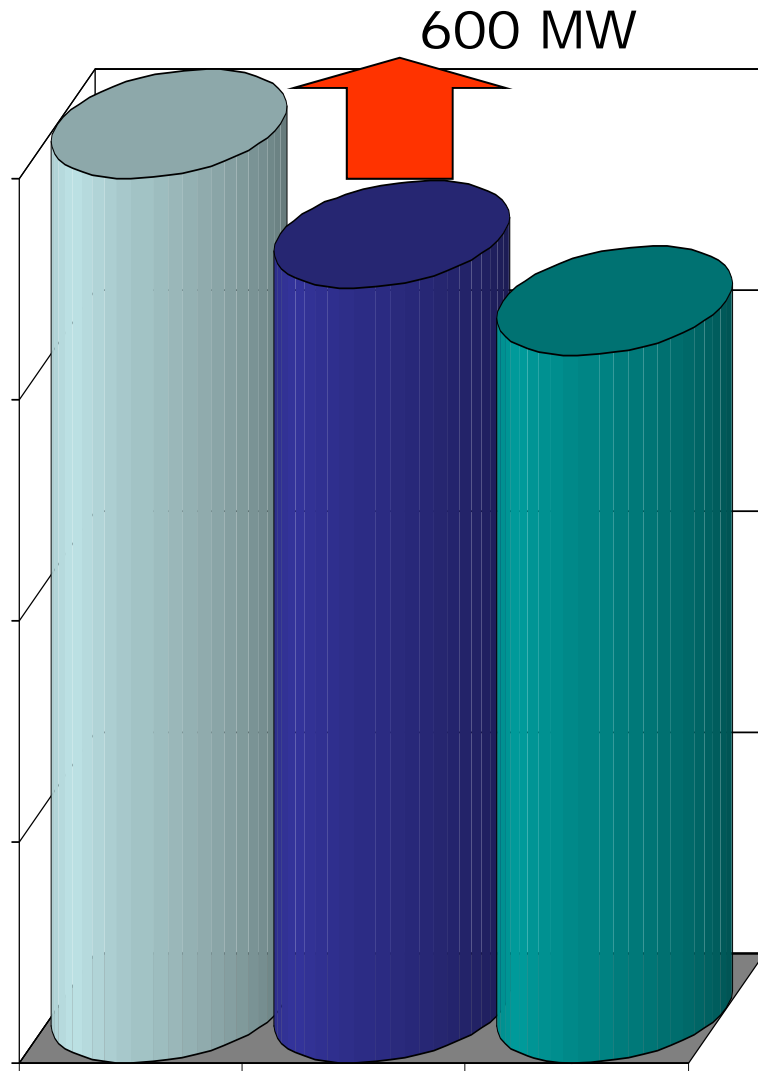

This demonstrates that

- if outage duration can reliably be reduced by 25%,
- the maintenance margin can be reduced
- and approx 1 unit (600MW) can be made available extra
- At low cost and quick (compared to investment /MWh

How much is this worth?



www.tocpractice.com



7th International TOCPA Conference
23-24 May 2013, South Africa



www.tocsa.co.za

But how?





PLAN vs EXECUTE

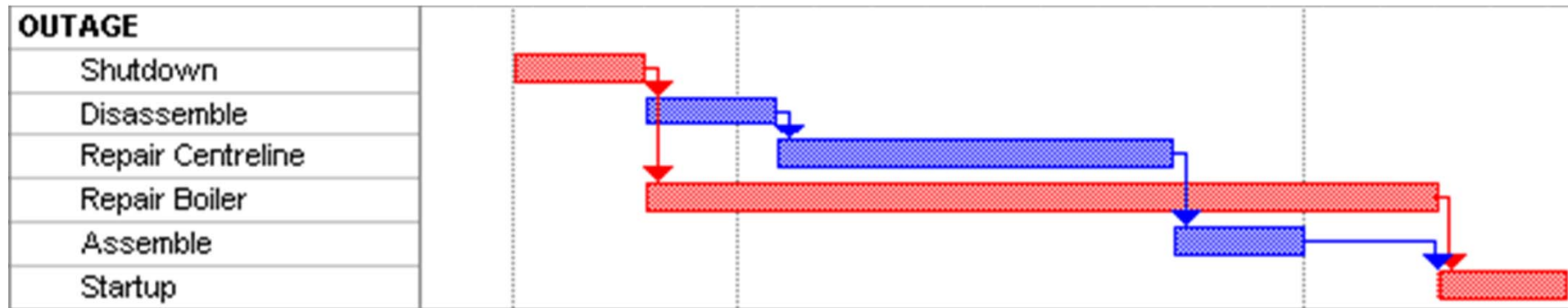

How much safety is included?



Any estimation above 50% embeds safety.

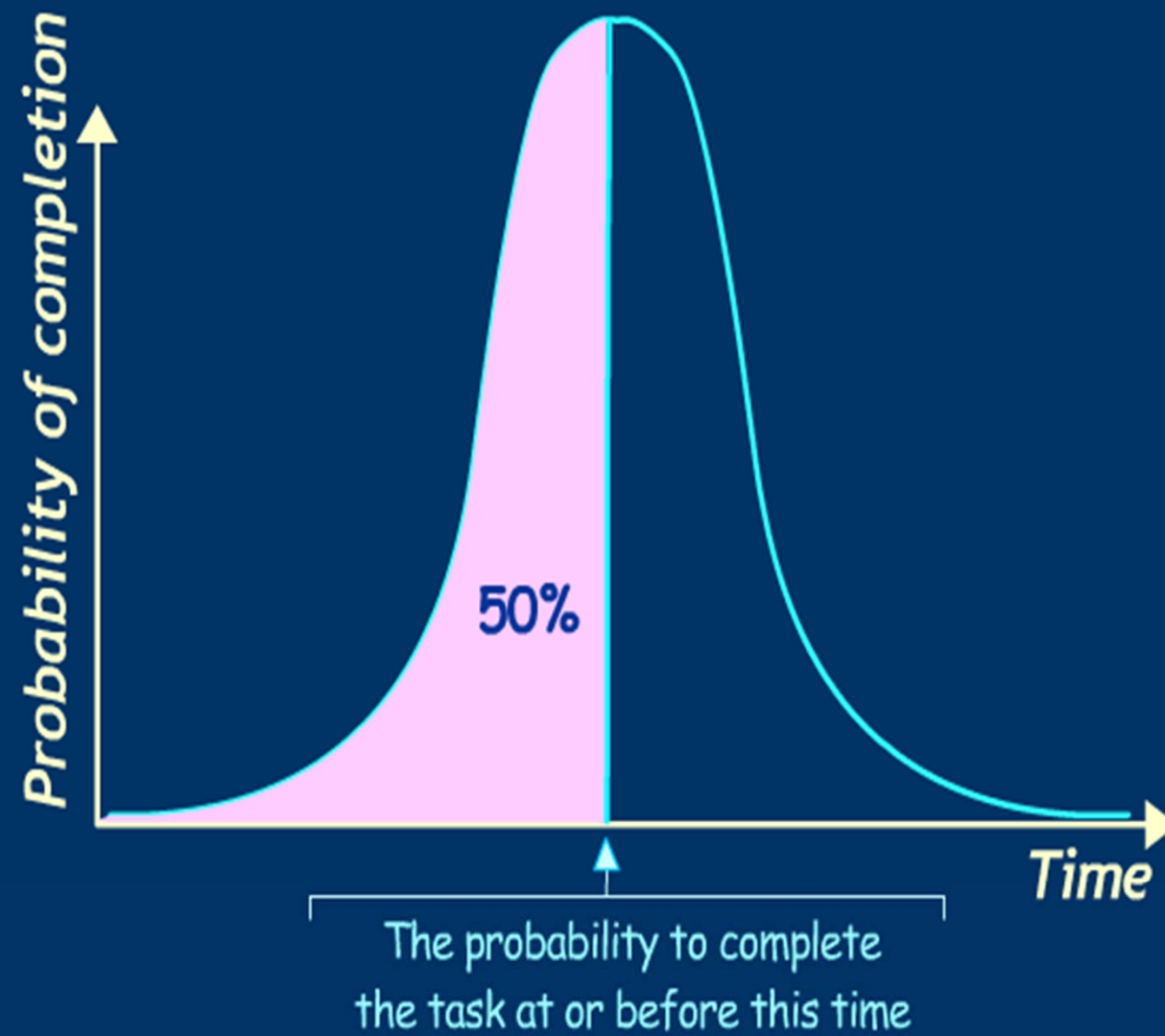

Any estimation above 50% embeds safety.

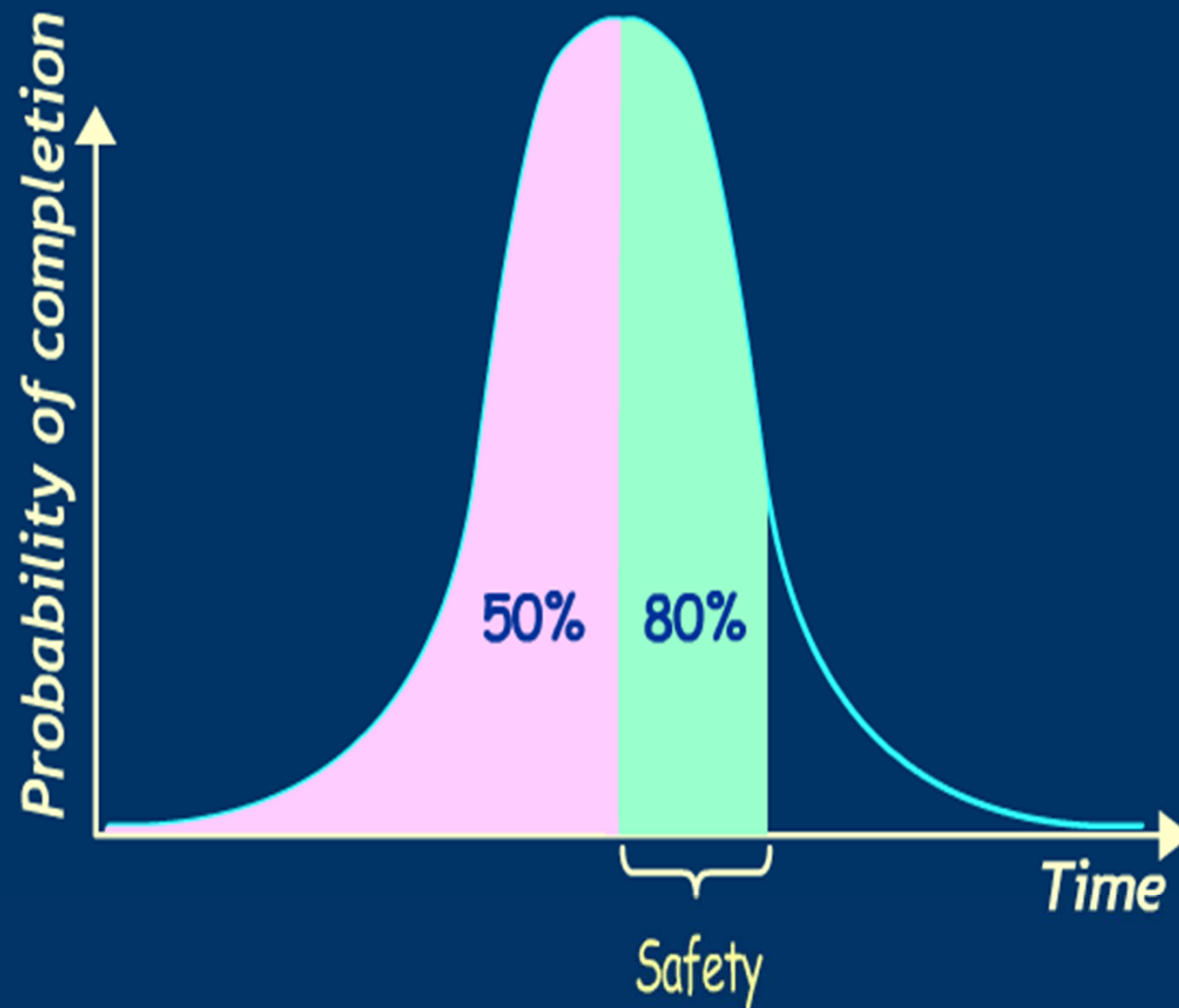

Choosing an estimation having 80% probability of completion,
adds relatively small safety.

In reality where uncertainty governs, the probability of completion is NOT symmetrical - it has a long tail. The higher the uncertainty the longer the tail.

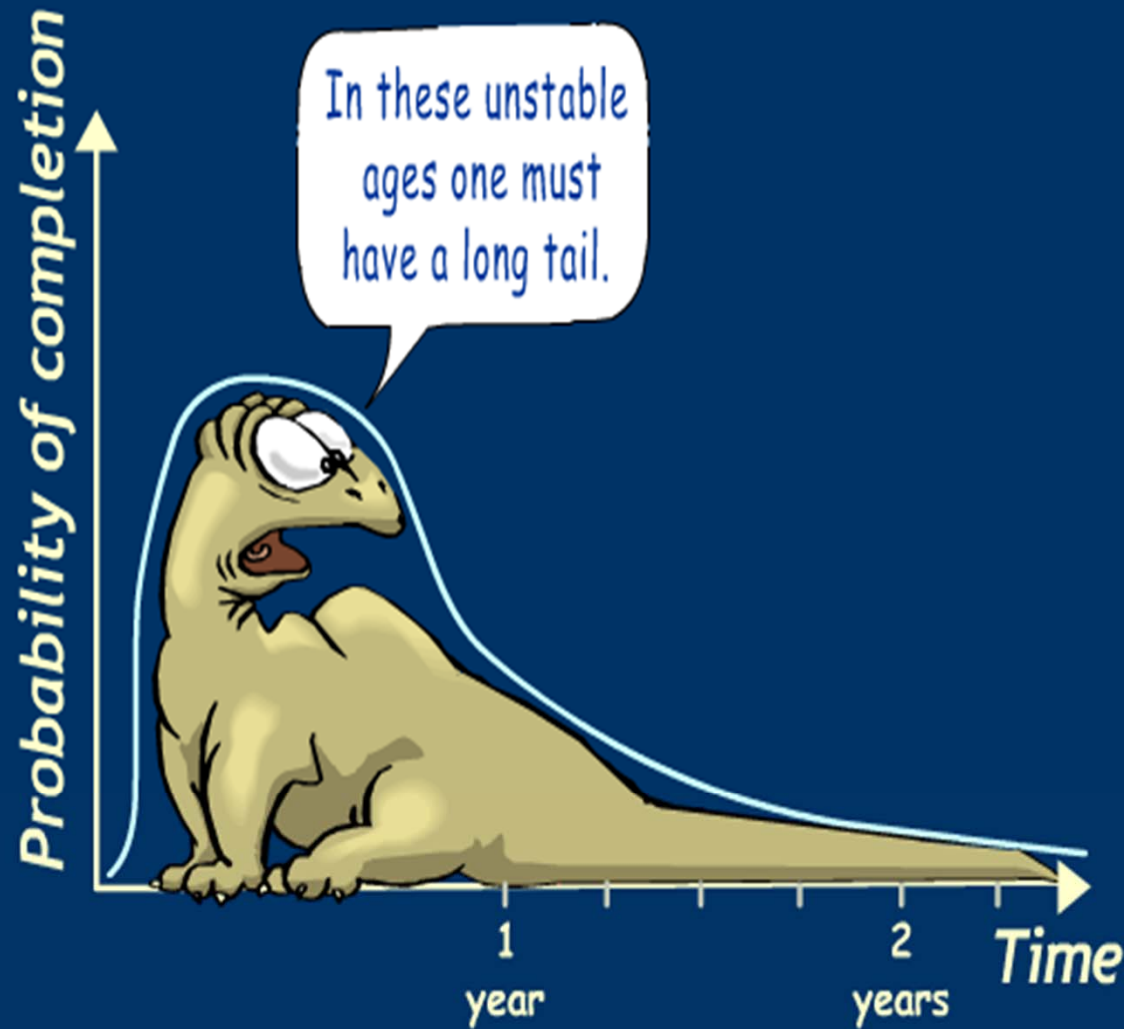

The safety added to estimations is further inflated - each level in the pyramid of hierarchy adds its own safety to the estimation.

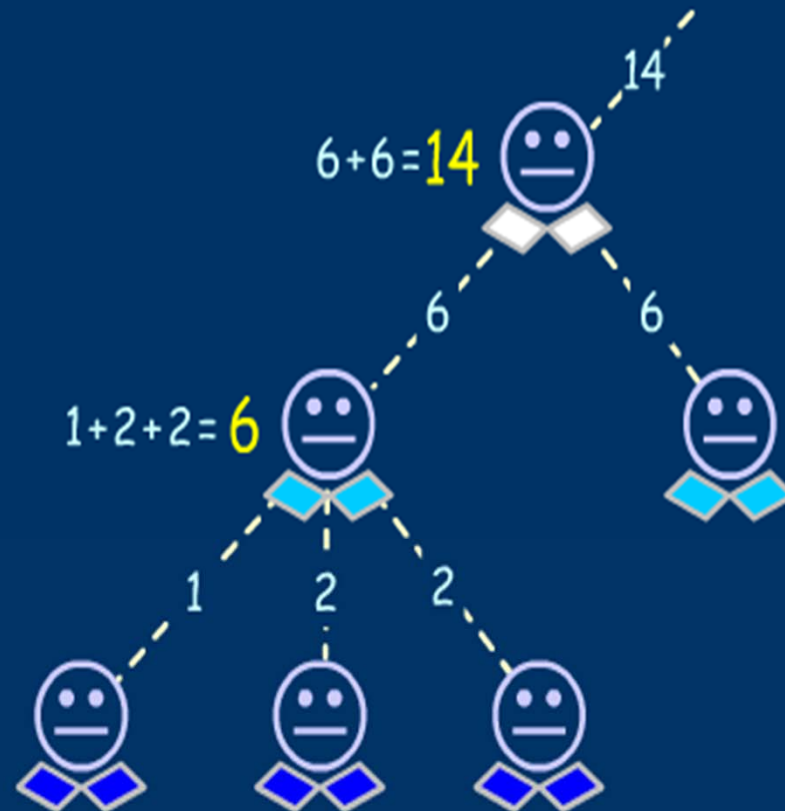



So the plan actually is...

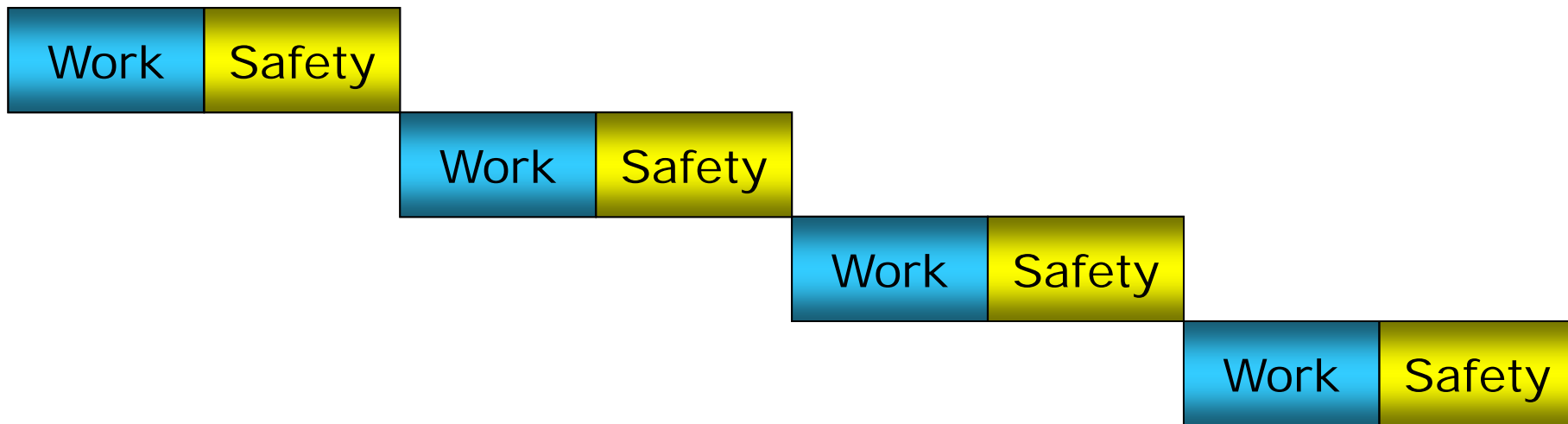

Then, why are we ever late?





1. Student syndrome



2. Parkinson syndrome

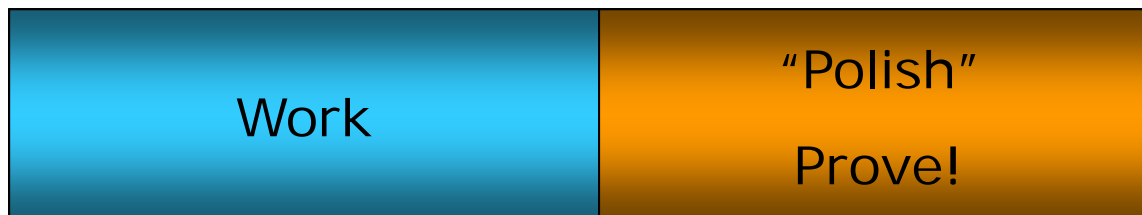

*Therefore, all delays propagate
and wins are few*





Therefore: Explicit buffers with aggressive plans

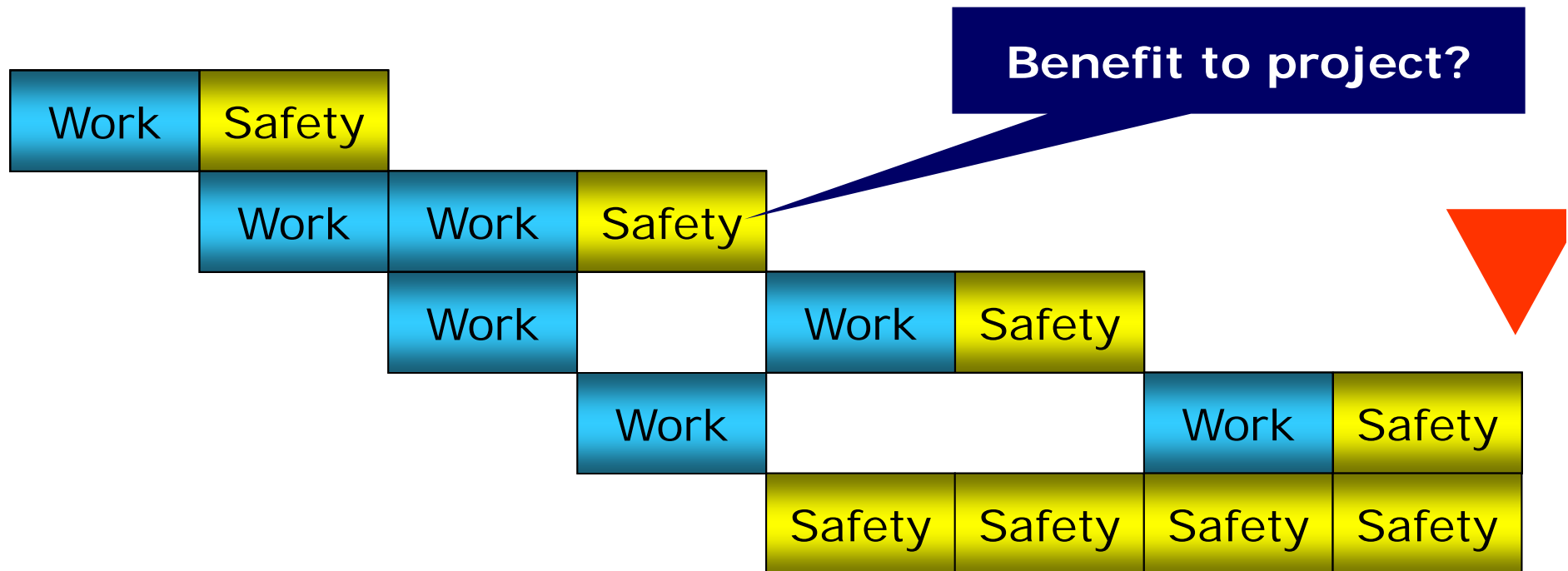



Test Case

- Methodology
 - Implement CCPM on outage projects
 - Briefing, training, executive liaison, negotiation
 - Project and buffer planning
 - Daily reporting and change management support
- Results
 - 25% duration optimisation is possible
 - Challenges and obstacles identified





Estimating Potential Benefits?

Per Outage Plan	70 days
Opportunity	20 - 30 days benefit
Benefits	>288 GWh (600MW x 24hrs)
Revenue	>R58 M (@R0.20/kWh)
Unserved Energy	>R23 B (@R80/kWh)

And

...the value of the extra unit on the grid?





Can CCPM create \$1B in value?...

- "The information contained in this publication by PwC is provided for discussion purposes only and is intended to provide the reader or his/her entity with general information of interest. The information is supplied on an "as is" basis and has not been compiled to meet the reader's or his/her entity's individual requirements. It is the reader's responsibility to satisfy him or her that the content meets the individual or his/ her entity's requirements. The information should not be regarded as professional or legal advice or the official opinion of PwC. No action should be taken on the strength of the information without obtaining professional advice. Although PwC take all reasonable steps to ensure the quality and accuracy of the information, accuracy is not guaranteed. PwC, shall not be liable for any damage, loss or liability of any nature incurred directly or indirectly by whomever and resulting from any cause in connection with the information contained herein."*

© PwC Inc. [Registration number 1998/012055/21]("PwC"). All rights reserved. PwC refers to the South African member firm, and may sometimes refer to the PwC network. Each member firm is a separate legal entity. Please see www.pwc.co.za for further details.

